



Ersatzteilunterlagen

HIMOTO RC-Cars MegaE 2WD Serie Maßstab 1:10

BashE Buggy	Bestell-Nr. 650044
Crazy ST Truggy	650046
BashE Brushless Buggy	650055
Crazy ST Brushless Truggy	650056



Crazy ST Truggy 2WD



BashE Buggy 2WD



Ersatzkarosserien

650881  Buggy Body (Black)	650883  Buggy Body (Red)	650882  Black Buggy Wing	650884  Red Buggy Wing
650886  Truggy Body (Red)	650887  Truggy Body (Green)	650888  Truggy Body (Blue)	

















<p>654701</p>  <p>Chassis BUGGY</p>	<p>654702</p>  <p>F/R Bottom Plate+Rear Shock Tower Mount+ Front Susp Mount+ Front Susp Pin Brace Pad</p>	<p>654703</p>  <p>Front Top Mount+Servo Arm+ Servo Mount</p>	<p>654704</p>  <p>Front Top Steering Mount</p>
<p>654705</p>  <p>Diff Gear Housing</p>	<p>654706</p>  <p>Diff Main Gear+Idler Gear+Diff Pinion Gear+ Diff Large/Small Bevel Gears+ Diff Inner Mount</p>	<p>654707</p>  <p>BUGGY TRUGGY Front Bumper+Motor Guard</p>	<p>654708</p>  <p>Gear Cover+Access Plug (Silicone Rubber)</p>
<p>654709</p>  <p>Rear Susp Pivot Block Set 1SET</p>	<p>654710</p>  <p>Battery Holder+Lock Pins+ Load Spring+Mount+ 2*8Mm Cap Head Screw</p>	<p>654711</p>  <p>F/R Shock Tower BUGGY</p>	<p>654712</p>  <p>Steering Mount Assembly+ Steering Ackerman Plate</p>
<p>654713</p>  <p>BUGGY L/R Front Susp Arms</p>	<p>654714</p>  <p>BUGGY L/R Rear Susp Arms</p>	<p>654715</p>  <p>L/R Steering Hubs</p>	<p>654716</p>  <p>L/R Front Uprights</p>
<p>654717</p>  <p>L/R Rear Uprights</p>	<p>654718</p>  <p>Enforced Pads Complete (Thick/Thin)</p>	<p>654719</p>  <p>BUGGY Wing Stay+Front Body Post</p>	<p>654726</p>  <p>Slipper Load Spring+ Slipper Spacer+M3 Nut+ Slipper Bushing+Slipper Washer</p>

<p>654727</p>  <p>Slipper Back Plate+Slipper Pad</p>	<p>654728</p>  <p>Steering Mount Assembly (Steering Bush, Servo Saver Load Spring, Steering Pad)</p>	<p>654729</p>  <p>Rear CVD Axles</p>	<p>654730</p>  <p>Diff Outdrives+2*2.5mm Countersunk Screw</p>
<p>654731</p>  <p>Front Axles+3Mm E-Clips</p>	<p>654732</p>  <p>Motor Plate</p>	<p>654733</p>  <p>Front Susp Pin Brace</p>	<p>654734</p>  <p>BUGGY 70.6mm Rear Drive Shafts</p>
<p>654735</p>  <p>Slipper Shaft+Transmission Upper Gear Shaft</p>	<p>654736</p>  <p>Steering Hub Hinge Pins (L=Approx. 23mm)</p>	<p>654737</p>  <p>26mm Front Lower Susp Hinge Pin (Outside)</p>	<p>654738</p>  <p>27.3mm Rear Lower Susp Hinge Pin (Outside)</p>
<p>654739</p>  <p>36.5mm Front Lower Susp Hinge Pin (Inside)</p>	<p>654740</p>  <p>48.5mm Rear Lower Susp Hinge Pin (Inside)</p>	<p>654741</p>  <p>Switch Mount</p>	<p>654742</p>  <p>Wheel Washers</p>
<p>654743 Inner Hole: Approx. 3.2MM FOR BRUSHED CARS ONLY</p>  <p>Motor Pinion (21T)+3*3mm Set Screw(0.6 Module)</p>	<p>654744 Inner Hole: Approx. 3.2MM FOR BRUSHED CARS ONLY</p>  <p>Motor Pinion (23T)+3*3mm Set Screw (0.6 Module)</p>	<p>654745 Inner Hole: Approx. 3.2MM FOR BRUSHED CARS ONLY</p>  <p>Motor Pinion (27T)+3*3mm Set Screw(0.6 Module)</p>	<p>654746</p>  <p>BUGGY Front Shock Absorbers</p>

<p>654747</p>  <p>BUGGY Rear Shock Absorbers</p>	<p>654748</p>  <p>BUGGY F/R Upper Adjustable Linkage Assembly</p>	<p>654749</p>  <p>BUGGY Front Steering Adjustable Linkage Assembly</p>	<p>654750</p>  <p>Servo Linkage Assembly</p>
<p>654751</p>  <p>Diff Complete+Idler Gear+Diff Pinion Gear+Ball Bearing 5*10*4Mm</p>	<p>654752</p>  <p>Spur Gear (77T)</p>	<p>654753</p>  <p>2.5*22mm 9*14*0.2mm 3*7*0.2mm Diff Pins+Shims</p>	<p>667736 1 Stück</p>  <p>Ball Bearings 3*6*2.5mm</p>
<p>616784</p>  <p>BUGGY Buggy Wing Pins</p>	<p>654815 (OPTIONAL PART)</p>  <p>BUGGY TRUGGY Wheelie Bar</p>	<p>654761</p>  <p>TRUGGY Chassis</p>	<p>654762</p>  <p>TRUGGY L/R Front Lower Susp Arms</p>
<p>654763</p>  <p>TRUGGY L/R Rear Lower Susp Arms</p>	<p>654764</p>  <p>TRUGGY F/R Shock Tower</p>	<p>654765</p>  <p>TRUGGY F/R Body Post & Mount</p>	<p>654766</p>  <p>TRUGGY Battery Holder/Lock Pins/Load Spring/Mount/2*8Mm Cap Head Screw</p>
<p>654767</p>  <p>TRUGGY Alum Capped Front Shock</p>	<p>654768</p>  <p>TRUGGY Alum Capped Rear Shock</p>	<p>654769</p>  <p>TRUGGY F/R Upper Adjustable Linkage Assembly</p>	<p>654770</p>  <p>TRUGGY Front Steering Adjustable Linkage Assembly</p>

<p>654771</p>  <p>TRUGGY Rear Drive Shafts (L=Approx.91.2Mm)</p>			
		<p>654059</p>  <p>4.8*4.9Mm Ball Stud 8P</p>	<p>616401</p>  <p>M3 Lock Nut 6P</p>
<p>616403</p>  <p>M4 Flange Lock Nut</p>	<p>667750 1 Stück</p>  <p>Ball Bearing 5*10*4Mm 6P</p>	<p>667789 1 Stück</p>  <p>Ball Bearing 10*15*4Mm 4P</p>	<p>654060</p>  <p>Front Turning Linkage Inserted Ball Stud 8P</p>
<p>616400</p>  <p>M2.5 Lock Nut 6P</p>	<p>616781</p>  <p>Body Clip A/B (Big) 12P</p>	<p>616782</p>  <p>Body Clip A/B (Small) 12P</p>	<p>646061</p>  <p>Wheel Hex Pin 8P</p>
<p>654755</p>  <p>Shock Ball Stud 8P</p>	<p>616854</p>  <p>F4.0 E-Clip 8P</p>	<p>616853</p>  <p>F3.0 E-Clip 8P</p>	<p>611680</p>  <p>Zip Tie (Big) 6P</p>

<p>652103</p>  <p>Zip Tie (Small) 8P</p>	<p>654065</p>  <p>Body Post Pad 12P</p>	<p>617430</p>  <p>Large Cross Wrench</p>	<p>617440</p>  <p>Gear Cover+Access Plug (Silicone Rubber)</p>
<p>653073</p>  <p>Round Head Self Tapping Screw 3*12 12P</p>	<p>616517</p>  <p>Round Head Self Tapping Screw 3*8 12P</p>	<p>646072</p>  <p>Round Head Self Tapping Screw 3*18Mm 12P</p>	<p>616547</p>  <p>Countersunk Self Tapping Screw 3*12 12P</p>
<p>616546</p>  <p>Countersunk Self Tapping Screw 2*15 12P</p>	<p>616252</p>  <p>3*3Mm Grub Screw 12P</p>	<p>646078</p>  <p>Round Head Self Tapping Screw 3*8 12P</p>	<p>653066</p>  <p>BUGGY TRUGGY Countersunk Self Tapping Screw 3*8 12P</p>
<p>646082</p>  <p>Countersunk Self Tapping Screw 2.6*8 12P</p>	<p>616541</p>  <p>Countersunk Self Tapping Screw 3*10 12P</p>	<p>616531</p>  <p>Round Head Self Tapping Screw 3*10 12P</p>	<p>616218</p>  <p>Cap Head Inner Hex Screw 2*8 12P</p>
<p>S034 auf Anfrage</p>  <p>Countersunk Screw 2*2.5 12P</p>	<p>616317</p>  <p>Round Head Screw 2.5*12 12P</p>	<p>S065 auf Anfrage</p>  <p>Round Head Screw 3*25 12P</p>	<p>616537</p>  <p>Round Head Self Tapping Screw 3*15 12P</p>

		<p>51011</p>  <p>Round Head Screw 2.5*8 12P</p>	<p>616153</p>  <p>Round Head Screw 3*10 12P</p>
<p>616505</p>  <p>Round Head Flange Self Tapping Screw 2.3*4 12P</p>	<p>S121 auf Anfrage</p>  <p>BUGGY TRUGGY Countersunk Screw 2.5*17 12P</p>	<p>S121 auf Anfrage</p>  <p>Small Round Head Screw 3*10 12P</p>	<p>616314</p>  <p>Round Head Screw 3*18.5 12P</p>
<p>S124 Auf Anfrage</p>  <p>Round Head Screw 2.5*22 12P</p>	<p>616231</p>  <p>Cap Head Screw 3*30 12P</p>	<p>616233</p>  <p>BUGGY TRUGGY Cap Head Screw 3*33.5 12P</p>	<p>654756</p>  <p>3*8Mm Round Head Screw+Shims 4P</p>
		<p>654780</p>  <p>Inner Hole: Approx.5MM FOR BRUSHLESS MOTOR ONLY</p> <p>Motor Pinion (19T)+3*3Mm Set Screw(0.6 Module)</p>	<p>654781</p>  <p>Inner Hole: Approx.5MM FOR BRUSHLESS MOTOR ONLY</p> <p>Motor Pinion (21T)+3*3Mm Set Screw(0.6 Module)</p>
<p>654782</p>  <p>Inner Hole: Approx.5MM FOR BRUSHLESS MOTOR ONLY</p> <p>Motor Pinion (23T)+3*3Mm Set Screw(0.6 Module)</p>	<p>654811</p>  <p>BUGGY (OPTIONAL PART) CVD Rear Shaft</p>	<p>654812</p>  <p>(OPTIONAL PART) CVD Rear Shaft TRUGGY</p>	<p>654818 (OPTIONAL PART)</p>  <p>BUGGY TRUGGY Metal Gear Complete</p>

<p>654722</p>  <p>BUGGY</p> <p>Off Road Front Rims</p>	<p>654720</p>  <p>BUGGY</p> <p>Off Road Front Tires+ Sponge Insert</p>	<p>654724</p>  <p>BUGGY</p> <p>Off Road Front Tire & Rim Complete</p>
<p>654723</p>  <p>BUGGY</p> <p>Off Road Rear Rims</p>	<p>654721</p>  <p>BUGGY</p> <p>Off Road Rear Tires+ Sponge Insert</p>	<p>654725</p>  <p>BUGGY</p> <p>Off Road Rear Tire & Rim Complete</p>
<p>654774</p>  <p>Round Hole</p> <p>TRUGGY</p> <p>Front Off Road Rim</p>	<p>654772</p>  <p>TRUGGY</p> <p>Off Road Front Tires w/Sponge</p>	<p>654776</p>  <p>TRUGGY</p> <p>Off Road Front Tire & Rim Complete</p>
<p>654775</p>  <p>Cross Hole</p> <p>TRUGGY</p> <p>Rear Off Road Rim</p>	<p>654773</p>  <p>TRUGGY</p> <p>Off Road Rear Tires w/Sponge</p>	<p>654777</p>  <p>TRUGGY</p> <p>Off Road Rear Tire & Rim Complete</p>

79098



HTX Sender 2 Kanal 2,4 GHz

79014

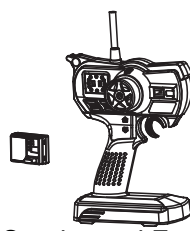

HTX Sender und Empfänger
2 Kanal 2,4 GHz

79088

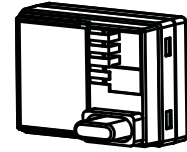

HTX Empfänger 2,4 GHz

42136 Nur bei der Standard Version enthalten

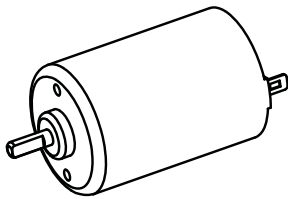

RC540 Motor

67028 Nur bei der Standard Version enthalten

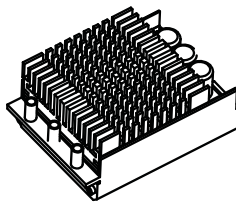

100A Fahrtregler

667218 Nur bei der Standard Version enth.



Akku NiMH(7.2V, 2000mAh)

79058

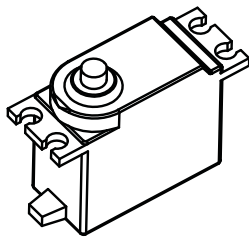

3Kg Servo

79064

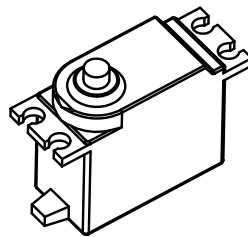

6Kg Servo

79512 Nur bei der Brushless Version enth.



Himoto A3 Ladegerät 230 V
für 2S/3S LiPo-Akkus

67035 Nur bei der Brushless Version enthalten

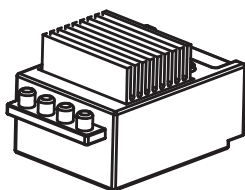

Brushless Fahrtregler 80 A

42409 Nur bei der Brushless Version enthalten

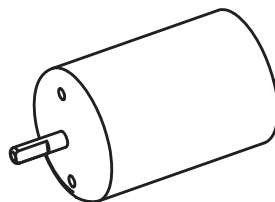

Brushless Motor 5 mm Welle

667224 Nur bei der Brushless Version enth.



LiPo-Akku mit GH4 Stecker
(7.4V, 2700 mAh)

79519

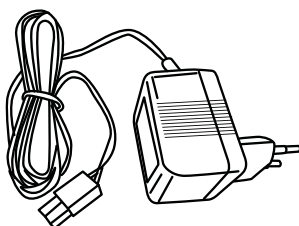

NiMH Ladegerät 230 V

Sinnvolle Ergänzungen zu den Fahrzeugen aus der E10 Serie

79513 Für alle Akkutypen verwendbar



Himoto E6650 Schnell-Ladegerät 12V/230V. Für Akku mit GH4 Stecker zusätzlich 79502 bestellen.

79502 Nur für Akkus mit GH4 Stecker verwendbar

Ohne
Abbildung

Ladekabel GH 4 mm
30 cm

956080 Nur für die Brushless-Version verwendbar



Stecker GH 4 mm lose zum umrüsten von Steckverbindungen / Akkus

956811 Nur für LiPo-Akkus verwendbar



RFI Unterspannungsalarm für 2-4 LiPo/Li-Ion Akkus

667219 Nur für die Standard-Version verwendbar



HIMOTO Racingpack 7,2V 3000 mA Tam.-Stecker. 50% längere Fahrzeit als mit dem serienm. Akku.

667224 Nur für die Brushless-Version verwendbar



HIMOTO Hardcase LiPo 7,4V 2700mA GH4. Ohne Umbaumaßnahmen verwendbar.

957143 Nur für die Standard-Version verwendbar



RFI Hardcase LiPo 7,4V 3200 mA Tam. Stecker. Benötigt LiPo Lader 79513 oder 79512

957142 Nur für die Brushless-Version verwendbar



RFI Hardcase LiPo 7,4V 3200 mA T-Plug 20C. Steckerverbindung muss auf GH4 umgelötet werden. Benötigt 956080

952190 Nur für die Brushless-Version verwendbar

Ohne
Abbildung

RFI Hardcase LiPo 7,4V 4000 mA T-Plug 25C. Gutes Preis/Leistungsverhältnis. Steckerverbindung muss auf GH4 umgelötet werden. Benötigt 956080

952510 Nur für die Brushless-Version verwendbar



RFI Hardcase LiPo 7,4V 5000 mA T-Plug 30C. Hochleistungsakku Steckerverbindung muss auf GH4 umgelötet werden. Benötigt 956080

957352 Nur für die Brushless-Version verwendbar

Ohne
Abbildung

RFI Hardcase LiPo 7,4V 6000 mA T-Plug 50C. Wettbewerbsakku. Steckerverbindung muss auf GH4 umgelötet werden. Benötigt 956080

957347 Nur für die Brushless-Version verwendbar

Ohne
Abbildung

RFI Hardcase LiPo 7,4V 6500 mA T-Plug 20C. Maximale Fahrzeit!! Steckerverbindung muss auf GH4 umgelötet werden. Benötigt 956080

Stoßdämpferöl Silicon 50 ml verschiedene Viskositäten

682005



682010



682015



682020



682025



682030



682040



682050



Je größer die Zahl der Viskosität (CPS) je zäher das Öl je höher die Dämpfungswirkung der Stoßdämpfer

Detailansichten

Servosaver

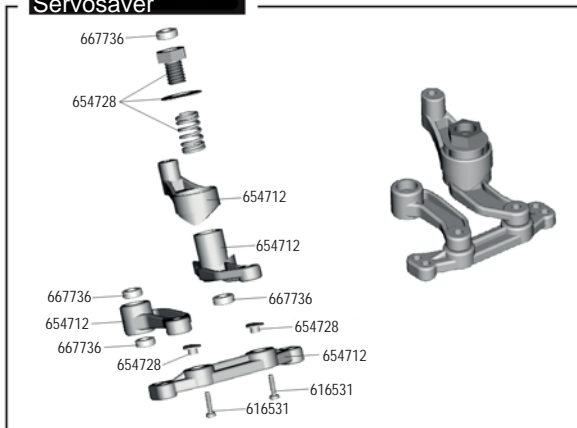

Batteriefachdeckel

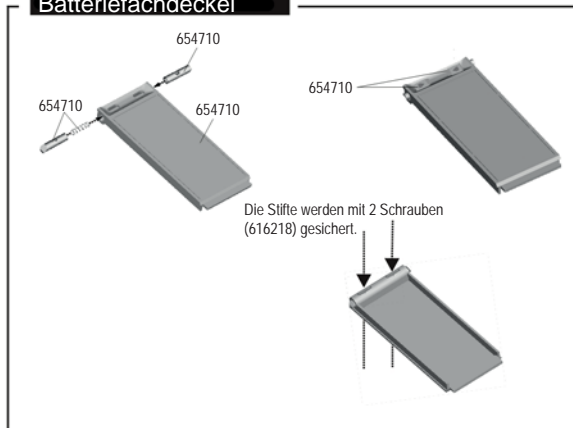

Differential

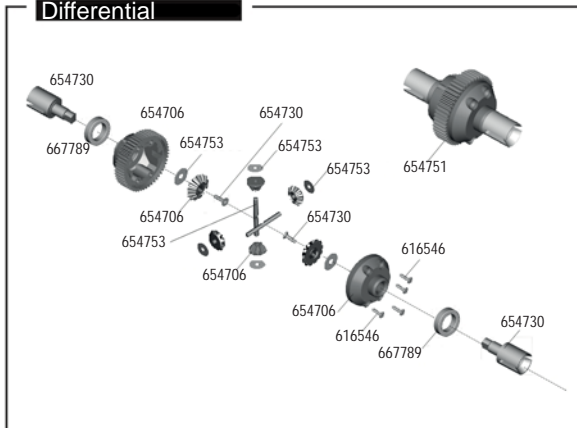

Getriebegehäuse

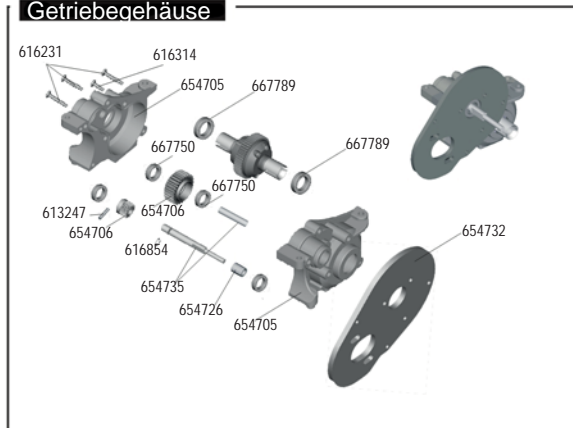

Slippermontage

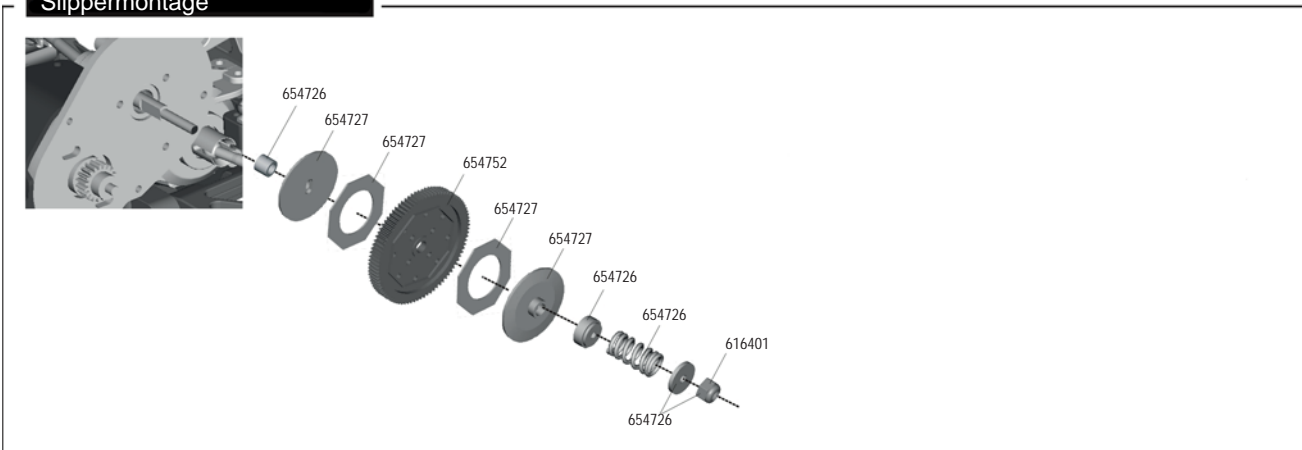

Ersatzteil-Explosionszeichnung HIMOTO BashE Buggy MegaE 2WD

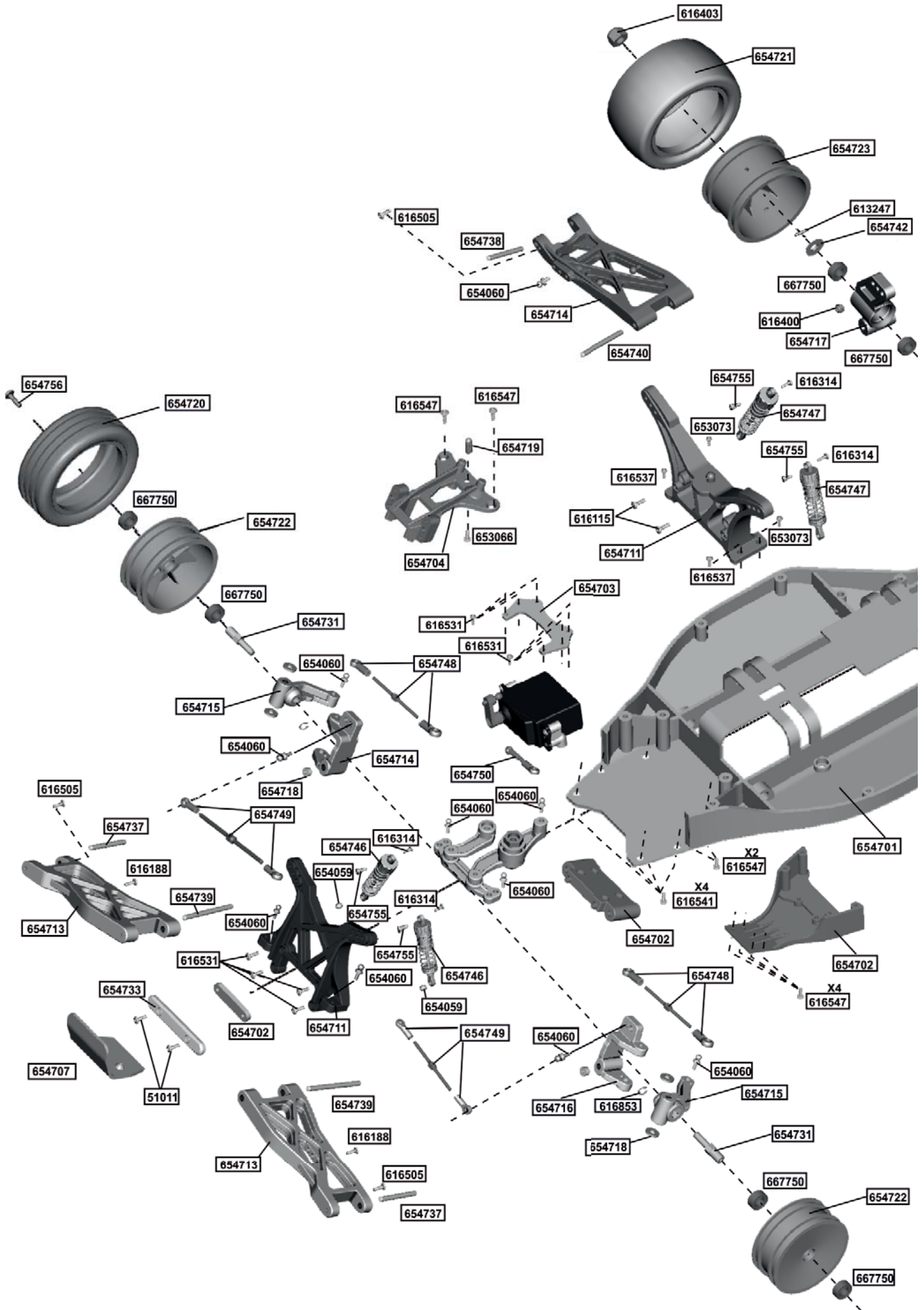

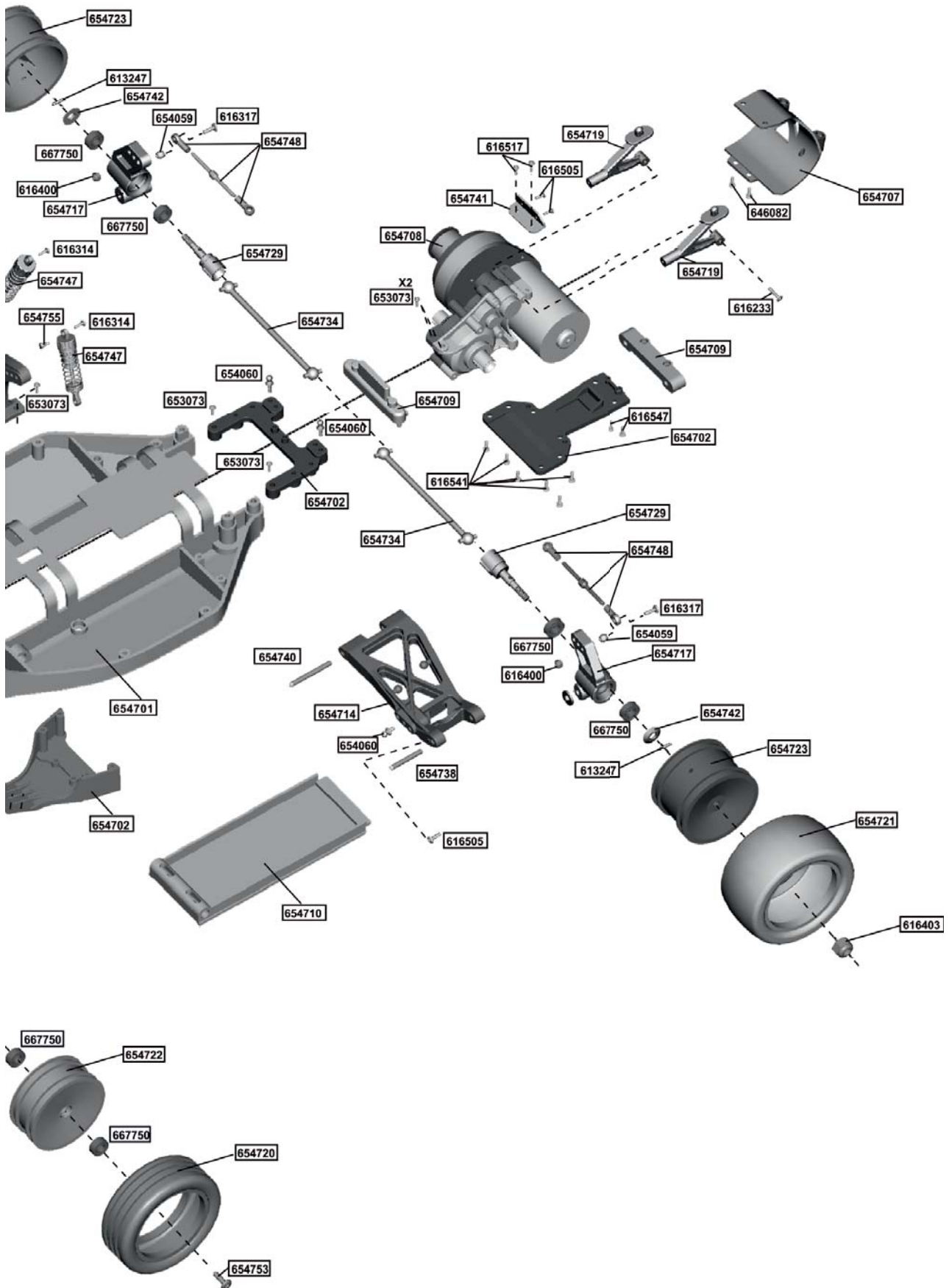

Ersatzteil-Explosionszeichnung HIMOTO Crazy ST Truggy 2WD

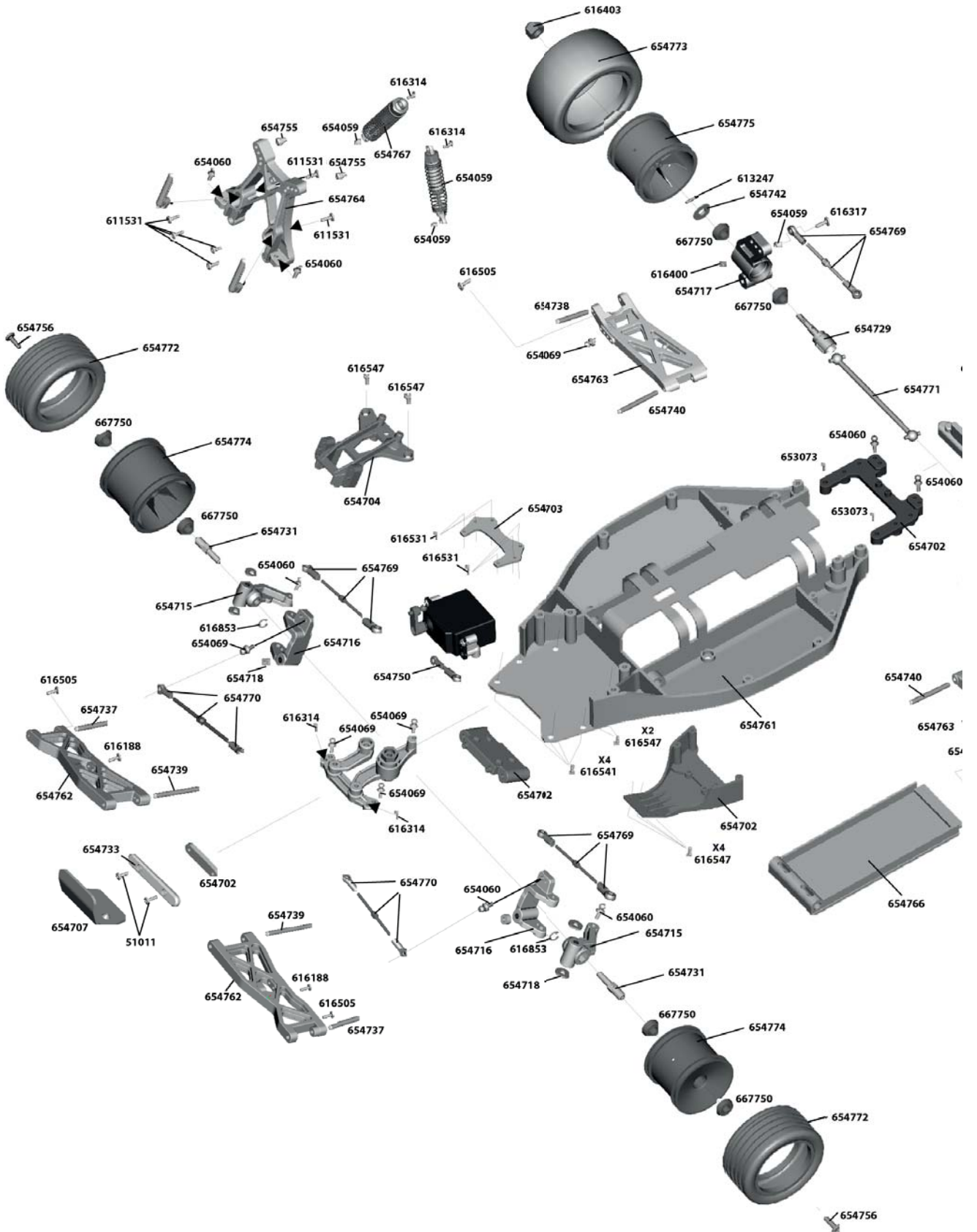

654775

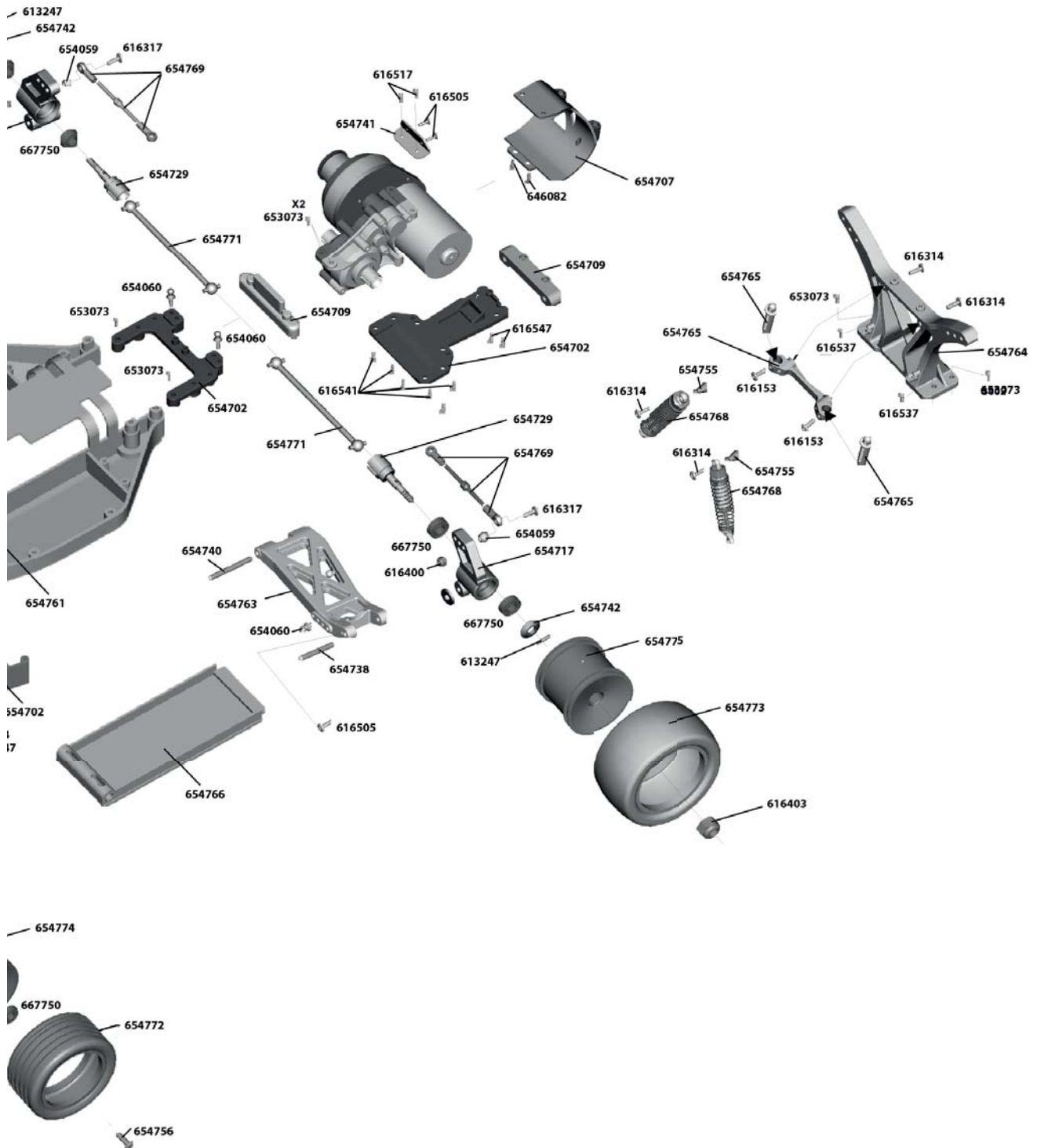



www.himoto-krick.de

Generalimporteur für Himoto Produkte

Krick Modelltechnik

Industriestrasse 1

75438 Knittlingen

Germany

E-Mail: info@krick-modell.de

Fax +49 (0)7043/31838